

Seasonal Dock For:  
**Wesley Scolaro**  
 388 Huckins Road  
 Freedom, NH. 03836  
 Plan prepared by:  
 Mark McConkey  
 on 6/2/2016

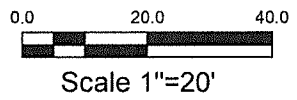

Picture 1

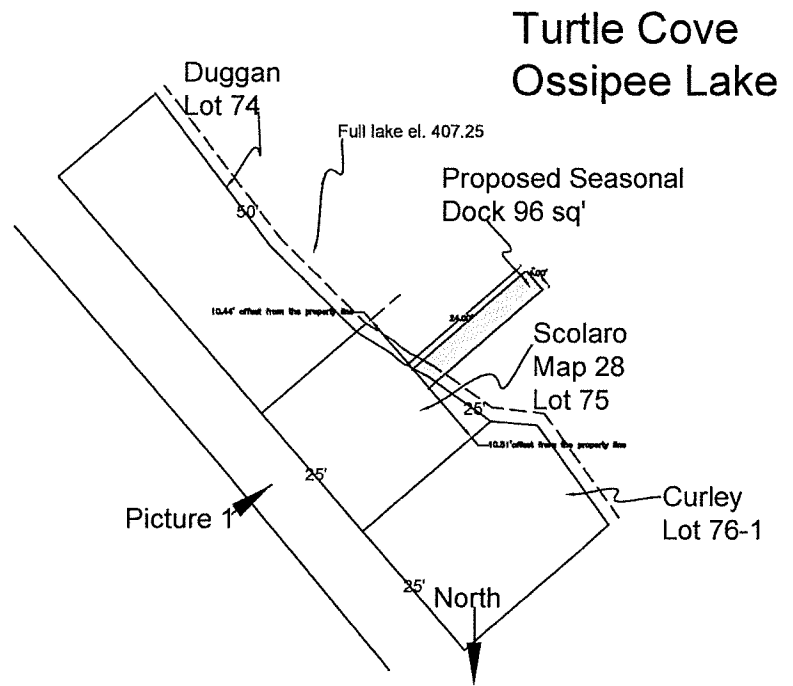

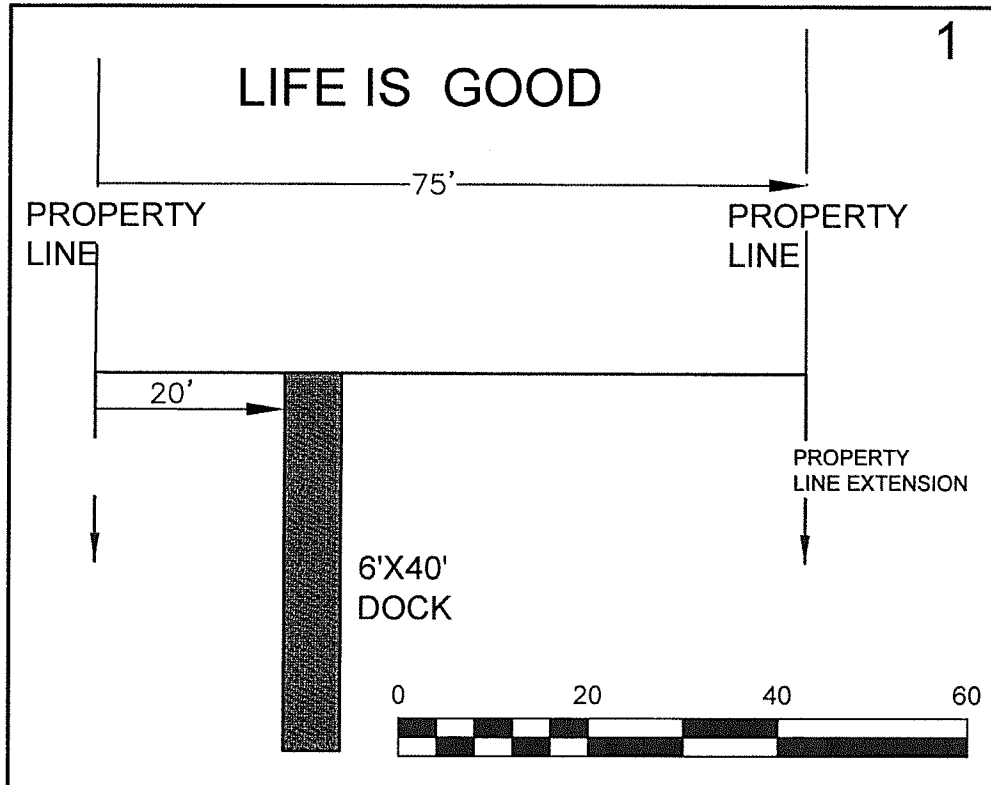

# SPINDLE POINT ON OSSIPEE LAKE

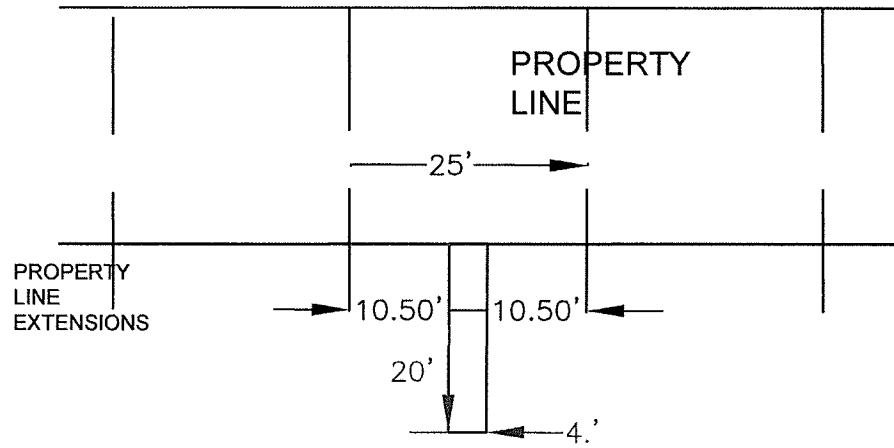

WITHOUT THE NEIGHBORS CONSENT  
NO DOCK IS POSSIBLE. LIFE IS BAD



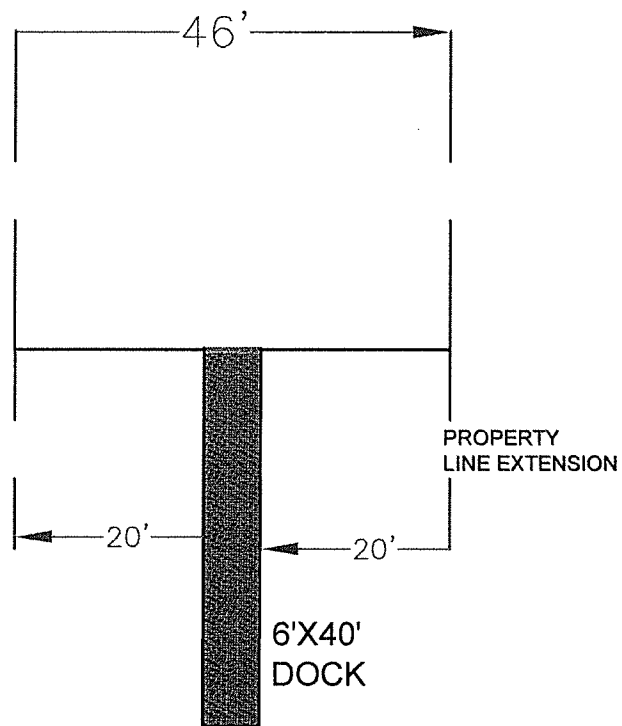

46' OF SHORELINE, LIFE MIGHT BE GOOD?



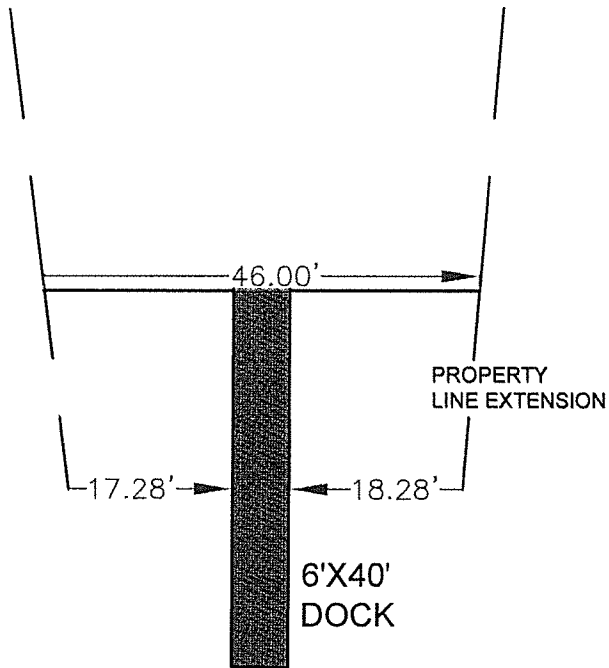

46' OF SHORELINE, LIFE IS NOW BAD !



## SUGGESTED DOCK OFFSETS FOR NARROWER LOTS

5

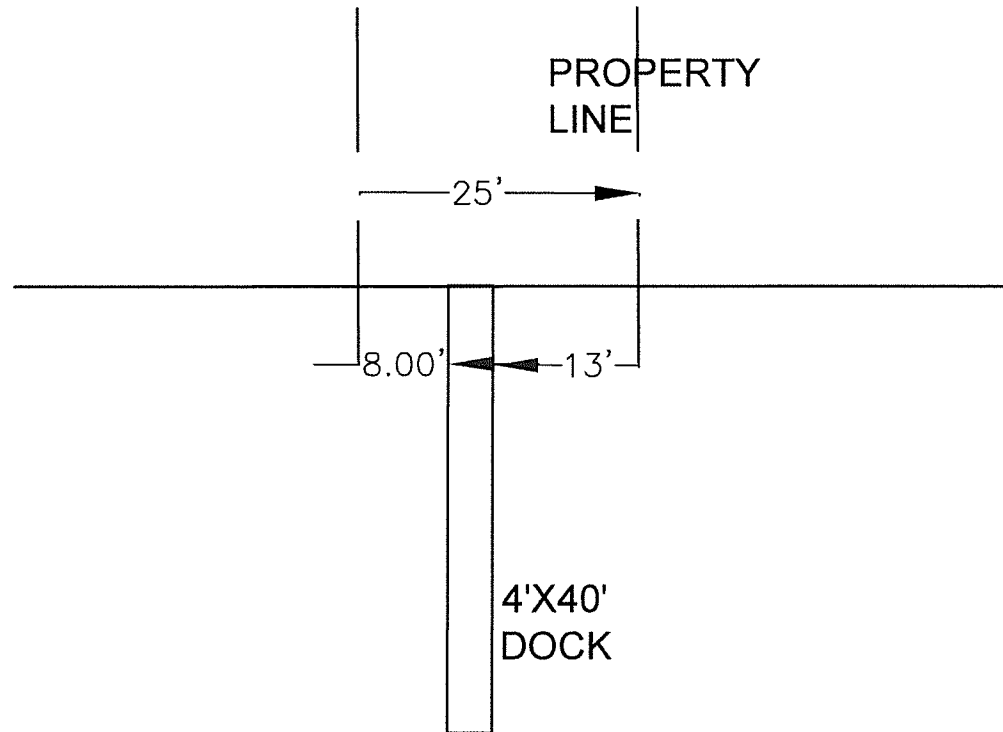

FOR NEW DOCKS: REMOVE THE REQUIREMENT TO USE A IMAGANARY PROPERTY LINE THAT EXTENDS OVER THE WATER. DEVELOP A NEW MATRIX USING LENGTH OF SHORELINE. FOR DOCKS WITH LESS THAN 46' OF SHORELINE, PERMIT A NARROWER SIZED DOCK THAT WILL ONLY PERMIT ONLY ONE SIDE OF THE DOCK TO BE USED TO TIE A BOAT TO.